

# RAK2287 WisLink LPWAN Concentrator Datasheet

## Overview

---

### Description

**RAK2287** is an LPWAN Concentrator Module with mini-PCIe form factor based on Semtech SX1302, which enables an easy integration into an existing router or other network equipment with LPWAN Gateway capabilities. It can be used in any embedded platform offering a free mini-PCIe slot with SPI connection. Furthermore, **ZOE-M8Q GPS chip** is integrated on board.

This module is an exceptional, complete and cost efficient gateway solution offering up to 10 programmable parallel demodulation paths, an 8 x 8 channel LoRa packet detectors, 8 x SF5-SF12 LoRa demodulators and 8 x SF5-SF10 LoRa demodulators. It is capable of detecting uninterrupted combination of packets at 8 different spreading factors and 10 channels with continuous demodulation of up to 16 packets. This product is best for smart metering fixed networks and Internet-of-Things (IoT) applications, that can cover of up to 500 nodes per km<sup>2</sup> in an environment of moderate interference.

### Features

- Designed based on **Mini PCL-e form factor** with Heat Sink.
- **SX1302 base band processor** emulates 8 x8 channel LoRa packet detectors, 8 x SF5-SF12 LoRa demodulators, 8 x SF5-SF10 LoRa demodulators, one 125 /250 / 500 kHz high-speed LoRa demodulator and one (G)FSK demodulator.
- 3.3v **Mini PCI-e**, compatible with 3G/LTE card of Mini PCI-e type.
- Compatible with **3G/LTE card** of Mini PCI-e type.
- Tx power up to 27dBm, Rx sensitivity down to -139dBm@SF12, BW 125 kHz.
- Supports **global license-free frequency band** (EU868,CN470, US915, AS923, AU915, KR920 and IN865).
- Supports optional SPI interfaces.
- Built-in **ZOE-M8Q GPS** module

### Specifications

---

#### Overview

The overview shows the top and back view of the RAK2287 board. It also presents the block diagram that discusses how the board works.

#### Board Overview

RAK2287 is a compact LPWAN Gateway Module, making it suitable for integration in systems where mass and size constraints are essential. It has been designed with the PCI Express Mini Card form factor in mind, so it can easily become a part of products that comply with the standard, where they allow for cards with thickness of at least 10.5 mm.

The board has two UFL interfaces for the LoRa and GNSS antennas and a standard 52 pin connector (mPCIe).

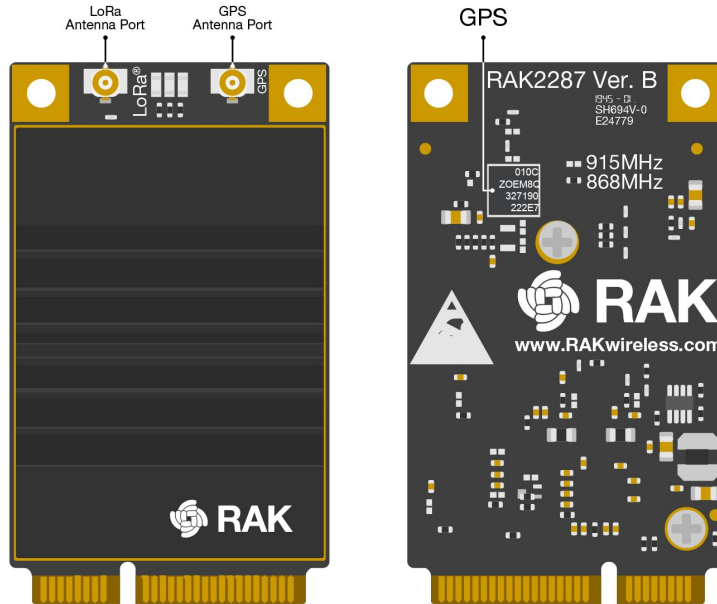

Figure 1: RAK2287 Board Overview

## Block Diagram

RAK2287 card is equipped with one SX1302 chip and two SX1250. The first chip is utilized for RF signal and the core of the device. While the latter, provides the related LoRa modem and processing functionalities. Additional signal conditioning circuitry is implemented for PCI Express Mini Card compliance, and one UFL connectors are available for external antennas integration.

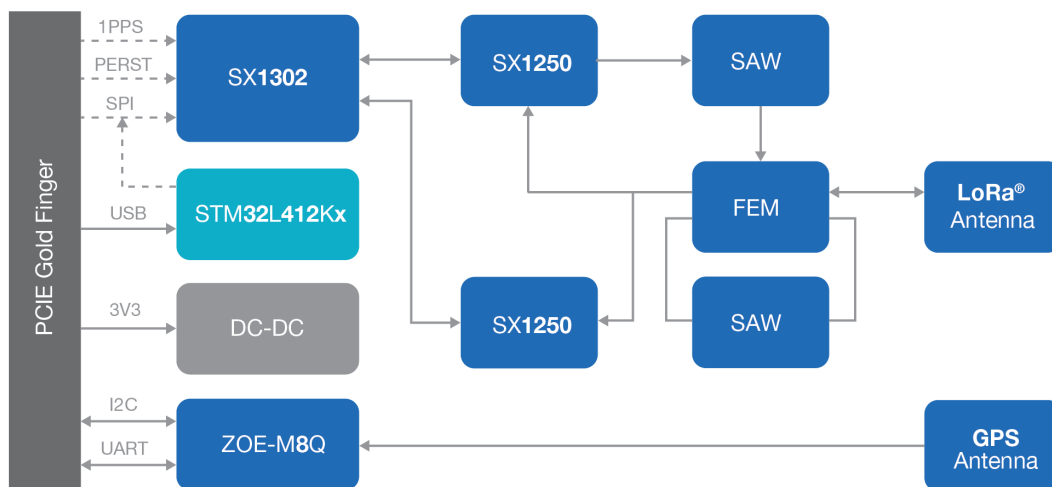

Figure 2: RAK2287 Block Diagram

## Hardware

The hardware is categorized into seven parts. It discusses the interfacing, pinouts and its corresponding functions and diagrams. It also covers the parameters and standard values of the board.

## Interface

### Power Supply

RAK2287 card must be supplied through the 3.3Vaux pins by a DC power supply. The voltage needs to be stable since the current drawn can vary significantly during operation based on the power consumption profile of the SX1302 chip (see [SX1302 Datasheet](#) )

### SPI Interface

SPI interface mainly provides for the Host\_SCK, Host\_MISO, Host\_MOSI, Host\_CSN pins of the system connector. The SPI interface gives access to the configuration register of SX1302 via a synchronous full-duplex protocol. Only the slave side is implemented.

## UART and I2C Interface

RAK2287 integrates ZOE-M8Q GPS module which has UART and I2C interface. The PINs on golden finger provide an UART connection and an I2C connection, which allows direct access to the GPS module. The PPS signal is not only connected to SX1302 internally, but also connected to golden finger which can be used by host board.

## GPS\_PPS

RAK2287 card includes the GPS\_PPS input for received packets time-stamped.

## RESET

RAK2287 card includes the RESET active-high input signal to reset the radio operations as specified by the SX1302 Specification.

## Antenna RF Interface

The modules have one RF interfaces over a standard UFL connectors (Hirose U. FL-R-SMT) with a characteristic impedance of 50Ω. The RF port (J1) supports both Tx and Rx, providing the antenna interface.

## Pin Definition

## Pinout Diagram



## RAK2287 SPI/USB PINOUT

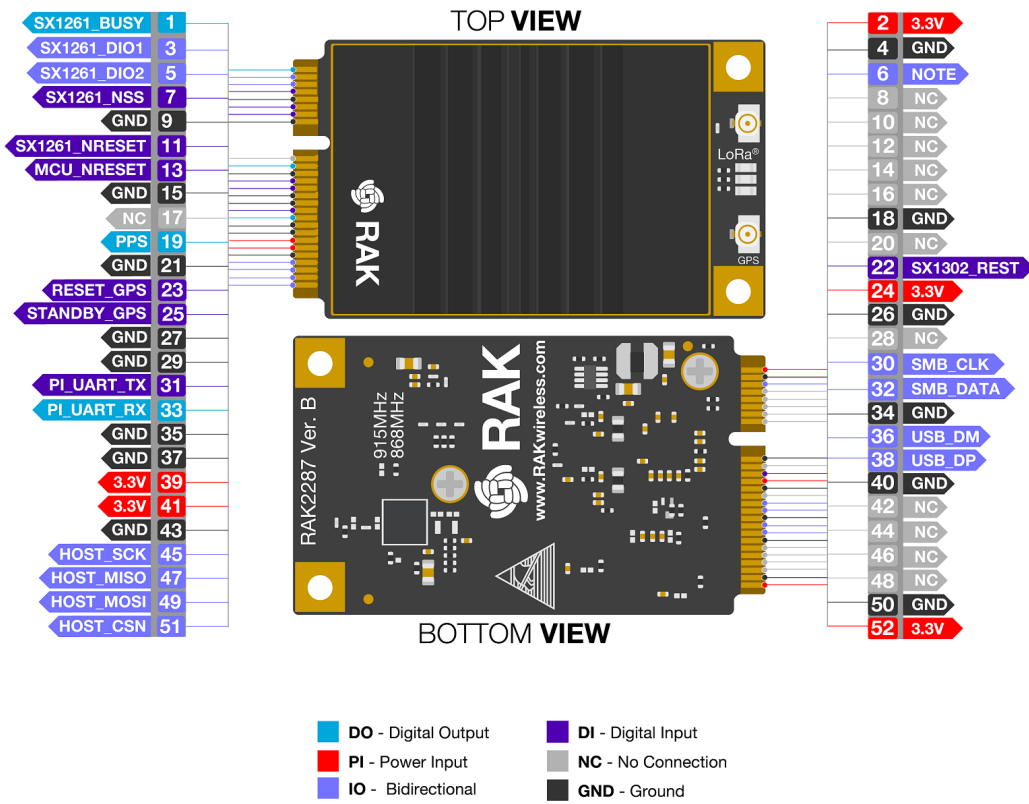

Figure 3: RAK2287 Pinout Diagram

## Pinout Description

Type	Description
IO	Bidirectional
DI	Digital input
DO	Digital output
OC	Open collector
OD	Open drain
PI	Power input
PO	Power output
NC	No Connection

Pin No.	Mini PCIe Pin Rev. 2.0	RAK2287 Pin	Type	Description	Remarks
1	WAKE#	NC		No Connection	
2	3.3Vaux	3V3	PI	3.3V DC supply	
3	COEX1	NC		No Connection	
4	GND	GND		Ground	
5	COEX2	NC		No Connection	
6	1.5V	GPIO(6)	IO		Connect to SX1302's GPIO[6].
7	CLKREQ#	NC		No Connection	
8	UIM_PWR	NC		No Connection	
9	GND	GND		Ground	
10	UIM_DATA	NC		No Connection	
11	REFCLK-	NC		No Connection	
12	UIM_CLK	NC		No Connection	
13	REFCLK+	MCU_NRESET	DI	No Connection by default	Reserved for future applications
14	UIM_RESET	NC		No Connection	
15	GND	GND		Ground	
16	UIM_VPP	NC		No Connection	
17	RESERVED	NC		No Connection	
18	GND	GND		Ground	
19	RESERVED	PPS	DO	Time pulse output	Leave open if not used.
20	W_DISABLE#	NC		No Connection	

Pin No.	Mini PCIe Pin Rev. 2.0	RAK2287 Pin	Type	Description	Remarks
21	GND	GND		Ground	
22	PERST#	SX1302_RESET	DI	RAK2287 reset input	Active high, $\geq 100\text{ns}$ for SX1302 reset.
23	PERn0	RESET_GPS	DI	GPS module ZOE-M8Q reset inputs	Active low, Leave open if not used.
24	3.3Vaux	3V3	PI	3.3V DC supply	
25	PERp0	STANDBY_GPS	DI	GPS module ZOE-M8Q external interrupt input	Active low, Leave open if not used.
26	GND	GND		Ground	
27	GND	GND		Ground	
28	1.5V	NC		No Connection	
29	GND	GND		Ground	
30	SMB_CLK	I2C_SCL	IO	HOST SCL	Connect to GPS module ZOE-M8Q's SCL internally. Leave open if not used.
31	PETn0	PI_UART_TX	DI	HOST UART_TX	Connect to GPS module ZOE-M8Q's UART_RX internally. Leave open if not used.
32	SMB_DATA	I2C_SDA	IO	HOST SDA	Connect to GPS module ZOE-M8Q's SDA internally. Leave open if not used.
33	PETp0	PI_UART_RX	DO	HOST UART_RX	Connect to GPS module ZOE-M8Q's UART_TX internally. Leave open if not used.
34	GND	GND		Ground	
35	GND	GND		Ground	
36	USB_D-	USB_DM	IO	USB differential data (-)	Require differential impedance of $90\Omega$ .
37	GND	GND		Ground	

Pin No.	Mini PCIe Pin Rev. 2.0	RAK2287 Pin	Type	Description	Remarks
38	USB_D+	USB_DP	IO	USB differential data (+)	Require differential impedance of 90Ω.
39	3.3Vaux	3V3	PI	3.3V DC supply	
40	GND	GND		Ground	
41	3.3Vaux	3V3	PI	3.3V DC supply	
42	LED_WWAN#	NC		No Connection	
43	GND	GND		Ground	
44	LED_WLAN#	NC		No Connection	
45	RESERVED	HOST_SCK	I/O	Host SPI CLK	
46	LED_WPAN#	NC		No Connection	
47	RESERVED	HOST_MISO	I/O	Host SPI MISO	
48	1.5V	NC		No Connection	
49	RESERVED	HOST_MOSI	I/O	Host SPI MOSI	
50	GND	GND		Ground	
51	RESERVED	HOST_CSN	I/O	Host SPI CS	
52	3.3Vaux	3V3	PI	3.3V DC supply	

## RF Characteristics

### Operating Frequencies

The board supports the following LoRaWAN frequency channels, allowing easy configuration while building the firmware from the source code.

Region	Frequency ( MHz )
Europe	EU868
North America	US915
Asia	AS923
Australia	AU915
Korea	KR920
Indian	IN865
China	CN470

## RF Characteristics

The following table gives typically sensitivity level of the RAK2287 card.

Signal Bandwidth / [KHz]	Spreading Factor	Sensitivity / [dBm]
125	12	-139
125	7	-125
250	7	-123
500	12	-134
500	7	-120

## Electrical Requirements

Stressing the device above one or more of the ratings listed in the Absolute Maximum Rating section may cause permanent damage. These are stress ratings only. Operating the module at these or at any conditions other than those specified in the Operating Conditions sections of the specification should be avoided. Exposure to Absolute Maximum Rating conditions for extended periods may affect device reliability.

The operating condition range define those limit within which the functionality of the device is guaranteed. Where application information is given, it is advisory only and does not form part of the specification.

## Absolute Maximum Rating

Limiting values given below are in accordance with the Absolute Maximum Rating System (IEC 134).



Symbol	Description	Condition	Min.	Max.
3.3Vaux	Module supply voltage	Input DC voltage at 3.3Vaux pins	-0.3V	3.6V
USB	USB D+/D- pins	Input DC voltage at USB interface pins		3.6V
RESET	RAK2287 reset input	Input DC voltage at RESET input pin	-0.3V	3.6V
SPI	SPI interface	Input DC voltage at SPI interface pin	-0.3V	3.6V
GPS_PPS	GPS 1 pps input	Input DC voltage at GPS_PPS input pin	-0.3V	3.6V
Rho_ANT	Antenna ruggedness	Output RF load mismatch ruggedness at ANT1		10:1 VSWR
Tstg	Storage Temperature		-40°C	85°C

#### WARNING

The product is not protected against overvoltage or reversed voltages. If necessary, voltage spikes exceeding the power supply voltage specification, given in table above, must be limited to values within the specified boundaries by using appropriate protection devices.

## Maximum ESD

The table below lists the maximum ESD.

Parameter	Min	Typical	Max	Remarks
ESD_HBM			1000V	Charged Device Model JESD22-C101 CLASS III
ESD_CDM			1000V	Charged Device Model JESD22-C101 CLASS III

#### NOTE

Although this module is designed to be as robust as possible, electrostatic discharge (ESD) can damage this module. This module must be protected at all times from ESD when handling or transporting. Static charges may easily produce potentials of several kilovolts on the human body or equipment, which can discharge without detection. Industry-standard ESD handling precautions should be used at all times.

## Power Consumption

Mode	Condition	Min.	Typical	Max.
Active-Mode(TX)	The power of TX channel is 27dBm and 3.3V supply.	511 mA	512 mA	513 mA
Active-Mode(RX)	TX disabled and RX enabled.	70 mA	81.6 mA	101 mA

## Power Supply Range

The table below lists the power supply range.

Input voltage at **3.3Vaux** must be above the normal operating range minimum limit to switch-on the module.

Symbol	Parameter	Min.	Typical	Max.
3.3Vaux	Module supply operating input voltage <sup>14</sup>	3 V	3.3 V	3.6 V

## Mechanical Characteristics

The board weighs 16.3 gram, it is 30 mm wide and 50.96 mm tall. The dimensions of the module fall completely within the **PCI Express Mini Card Electromechanical Specification**, with except of the card's thickness (10.5 mm at its thickest).

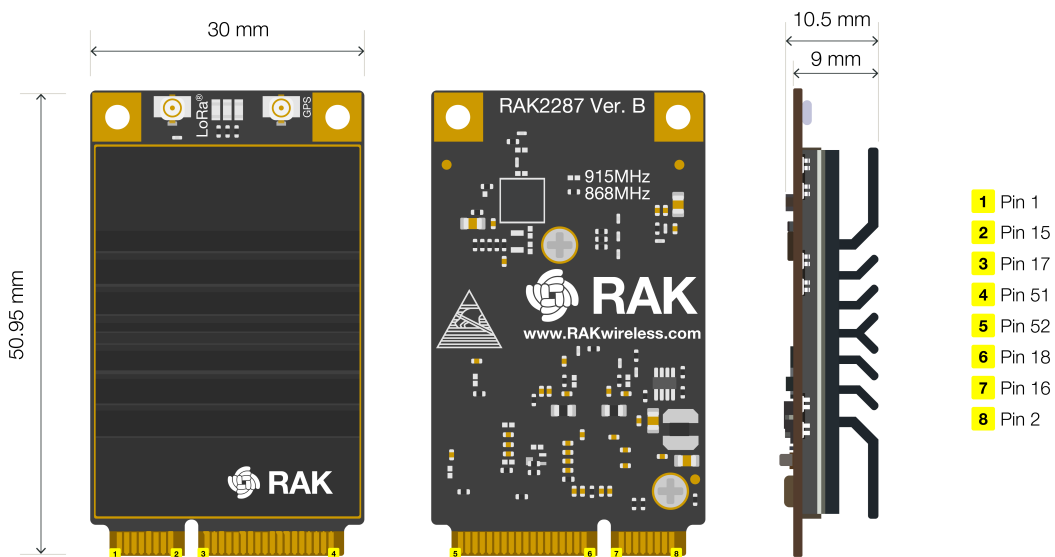

Figure 4: RAK2287 Board Dimensions

## Environmental Requirements

### Operating Conditions

The table below lists the operation temperature range

Parameter	Min.	Typical	Max.	Remarks
Normal operating temperature	-40°C	+25°C	+85°C	Normal operating temperature range (fully functional and meet 3GPP specifications)

**NOTE**

Unless otherwise indicated, all operating condition specifications are at an ambient temperature of 25°C. Operation beyond the operating conditions is not recommended and extended exposure beyond them may affect device reliability.

## Schematic Diagram

RAK2287 card refers to Semtech's reference design of SX1302. The SPI interface can be used on PCIE connector. The next figure shows the minimum application schematic of RAK2287 card. You should use it at least 3.3V/1A DC power, connect SPI interface interface to the main processor.

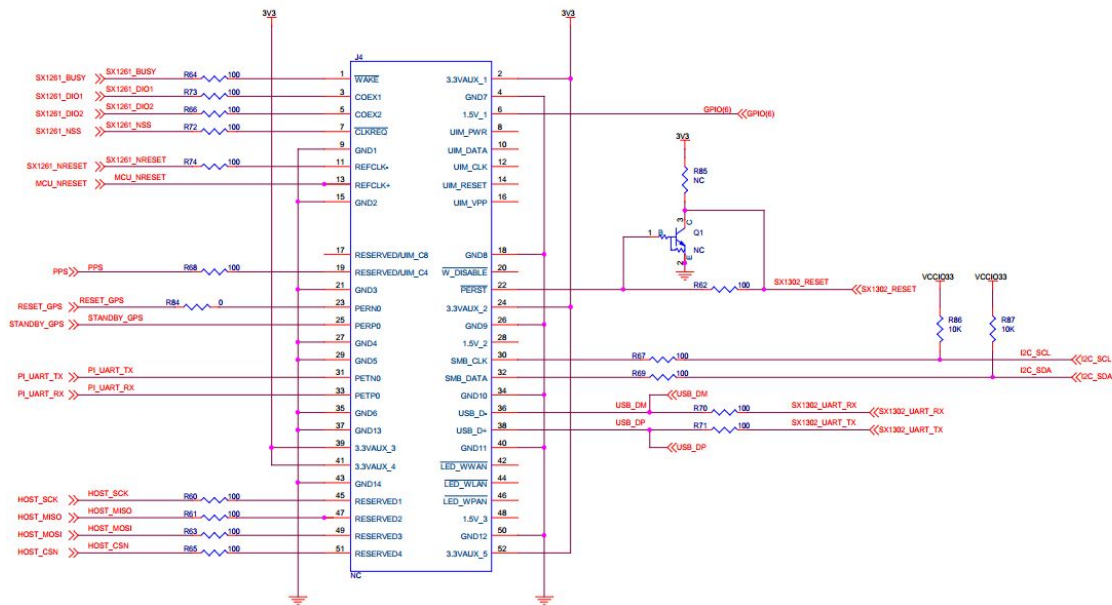

Figure 5: Schematic Diagram of RAK2287

## Software

Download the latest firmware of the RAK2287 WisLink-LoRa in the table provided below.

## Firmware

Model	Raspberry Pi Board	Firmware Version	Source
RAK2287	Raspberry Pi 3B+, 4	V4.2.5_20200909	<a href="#">Download</a>

## Models / Bundles

### Order Information

In general, the RAK2287's variation is the defined as **RAK2287 - XY**, where **X is the model variant** and **Y is the supported region**. Take a look at the tables below to know the variants and its individual specification.

Parameter	Variations
X - Model Variant	S; M; A; C
Y - Supported Region	3 - EU868; 4 - US915; 5 - KR920; 6 - AS923; 7 - IN865; 8 - AU915

The table below shows the board order configurations of the RAK2287 WisLink LPWAN Concentrator.

Model	SX1302 on board	STM32L412Kx on board	GPS module on board	SPI Interface	USB Interface
RAK2287-SY	√		√	√	
RAK2287-MY	√			√	
RAK2287-AY	√	√	√		√
RAK2287-CY	√	√			√

## Certification



Last Updated: 7/28/2021, 5:13:12 AM